

STRUCTURAL STRAND BOOM PENDANT SPECIFICATIONS AND REQUIREMENTS REQUEST



Please complete for quote and order accuracy.

1. General Information

QUANTITY _____ DIAMETER _____
 LENGTH _____ MEASURING POINTS _____
 (Example: C-Pin to C-Pin)

2. Choose the Galvanized Class: (check one)

A (Throughout) B (B outer/A inner) C (C outer/A inner)

3. Length Tolerance: (check one)

Prestretch? Yes No
 Stripe? Yes No
 Measure length under load? Yes No

4. Socket Specifications:

Lube tubes? Yes No

Strand Socket (on one end)

Pin diameter (D) _____

Jaw opening (O) _____

Ear thickness (V) _____

C-pin to basket (M) _____

Bail: Thickness (K) _____

Bail: Inside width (W) _____

Bail: Inside length (L) _____

Special dimensions not noted: _____

Special packaging required: _____

Strand Socket (on one end)

Pin diameter (D) _____

Jaw opening (O) _____

Ear thickness (V) _____

C-pin to basket (M) _____

Bail: Thickness (K) _____

Bail: Inside width (W) _____

Bail: Inside length (L) _____

5. Select your configuration: (circle one)

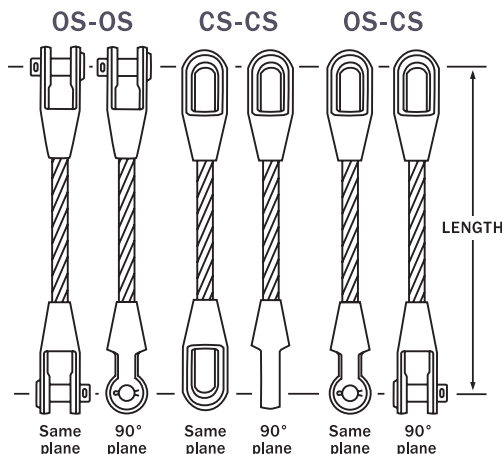

CLOSED STRAND SOCKET (CSS)

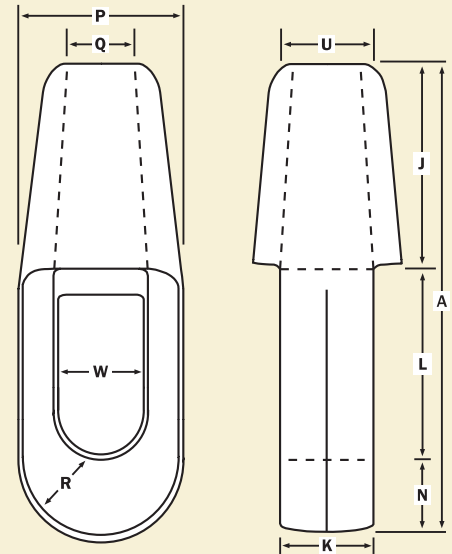

OPEN STRAND SOCKET (OSS)

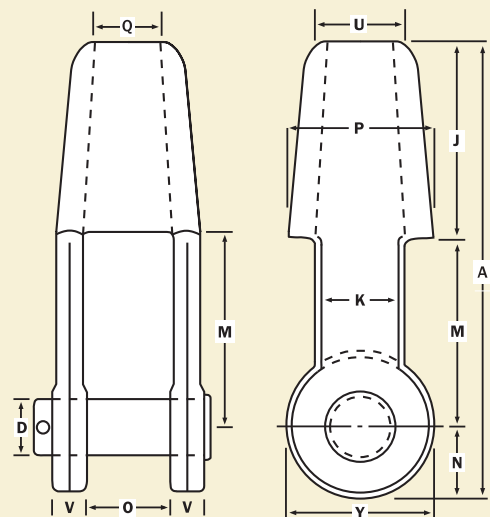

WireCo® WorldGroup
 12200 NW Ambassador Dr.
 Kansas City, MO 64163-1244
 T (816) 270-4700
 F (816) 270-4704
 info@WireCoWorldGroup.com
 unionrope.com